

Galley® Line

Sanitary, Heavy Duty
Undercounter
Heated Modules

Item No. _____

Model No. 9035
Model No. 9045
Model No. 9055

A1A11420



U.S. Patent No's. 4,008,931,244,735 AND OTHER PATENTS PENDING.

Heated Base Utility Counter - Perfect for additional storage of heated foods. Add Galley drop-in hot wells for serving all out of one module.

- Aesthetic design, three neutral colors, dove white, pewter tan and black pearl blends in with any surroundings.
- Four built-in & concealed stainless steel handles allow easy portability.
- Self-locking and self-aligning features eliminate time consuming hookup.
- Lightweight but extra-strong construction provides ease of mobility.
- Casters and brakes are almost completely concealed from patron's view.
- Soft textured surfaces and rounded corners help prevent skin cuts and clothing snags.

To be **Galley® Line** Heated Base Module, Model _____ with accessories as specified.

GENERAL: Unit to be self-contained, mobile undercounter heated module accessible from server side only. Body material to be one of three neutral base colors, dove white, pewter tan or black pearl. "Matelock" self-locking and aligning end panels allow modules to be interconnected. To have recessed push handles at each end. Side skirt (customer side) to be removable for access to electrical junction box and heated base. Side skirt to be recessed to accept decorator panels.

CONSTRUCTION: Body material to be of flame retardant ABS formed plastic fastened to galvanized steel under-carriage. 14 ga. 300 series stainless steel top to have not less than #4 finish. Inner

liner of heated cabinet constructed of stainless steel. This heated base section can be used for both additional storage and back up food service preparation. This base section will maintain the proper holding and serving temperature for food throughout the serving period. The base section is furnished with a separate thermostat and 850 watt element to provide maximum efficiency. Plate mounted 4" diameter swivel casters with toe brakes to be provided. Power supply cord to be 6 feet in length. NEMA plug configuration to be 5-15P. To be used with a branch circuit rating of 15 amps, single pole. Power supply cord to be 14 AWG, 3 conductors. Doors fully insulated with edge mount hinge and slam action latch. Complete with moisture proof door gasket, removable false bottom and removable pan side rack for easy cleaning. Holds 12" x 20" pans.

Cat. No.	Module Size			Quantity of Decorator Panels Included	12" x 20" x 2 ⁵ / ₈ " Pan Capacity	Unit Electrical Ratings				Shpg. Wt. Lbs.
	W	D	H			Volts	Amps	Phase	Hz	
9035	50"	28"	36"	3	8	120	6.8	1	60	500
9045	64 1/2"	28"	36"	4	12	120	6.8	1	60	550
9055	79"	28"	36"	5	16	120	6.8	1	60	650

NOTE: If unit is to be used independently, add 4" to width for clearance on all specifications. Add 3 1/2" to depth for folded trayslide and 3 1/4" for folded cutting board.

Galley® Line

Undercounter Heated Modules

Model No. 9035

Model No. 9045

Model No. 9055

ACCESSORIES:

A. Decorator panels, specify catalog number. (See chart).

- | | |
|---|--|
| <input type="checkbox"/> Catalog No. 8700 American Walnut. | <input type="checkbox"/> 8704 White |
| <input type="checkbox"/> Catalog No. 8701 Teakwood. | <input type="checkbox"/> 8705A Light Oak |
| <input type="checkbox"/> Catalog No. 8702 Plain Custom Panel. | |

B. Folding Trayslides. All stainless steel with die-stamped three-rib reinforcement.

- | |
|--|
| <input type="checkbox"/> Catalog No. 8774, 50" width. |
| <input type="checkbox"/> Catalog No. 8775, (*Short 64 1/2") 57 3/8" width. |
| <input type="checkbox"/> Catalog No. 8776, 64 1/2" width. |
| <input type="checkbox"/> Catalog No. 8777, (*Short 79") 71 7/8" width. |
| <input type="checkbox"/> Catalog No. 8778, 79" width. |

***Note:** A short trayslide must be used on the first module to the right of Corner In-Fill Module for inside turns.

C. Food Protector with plastic shelf, breathguard and stainless steel upright supports. 14" high. Must be factory ordered with the refrigeration module.

- | |
|---|
| <input type="checkbox"/> Catalog No. 8780 50" width. Unlighted. |
| <input type="checkbox"/> Catalog No. 8791 50" width. Lighted. |
| <input type="checkbox"/> Catalog No. 8781 64 1/2" width. Unlighted. |
| <input type="checkbox"/> Catalog No. 8792 64 1/2" width. Lighted. |
| <input type="checkbox"/> Catalog No. 8782 79" width. Unlighted. |
| <input type="checkbox"/> Catalog No. 8793 79" width. Lighted. |

D. Double-Deck Display Stand with two plastic shelves, breathguards and stainless steel upright supports. 14" high. Must be factory ordered with the refrigeration module.

- | |
|---|
| <input type="checkbox"/> Catalog No. 8785 50" width. Lighted. |
| <input type="checkbox"/> Catalog No. 8786 64 1/2" width. Unlighted. |
| <input type="checkbox"/> Catalog No. 8789 64 1/2" width. Lighted. |
| <input type="checkbox"/> Catalog No. 8787 79" width. Unlighted. |
| <input type="checkbox"/> Catalog No. 8788 Unlighted. |
| <input type="checkbox"/> Catalog No. 8790 79" width. Lighted. |

E. Folding Cutting Board. All plastic. Mounted flush on server's side.

- | |
|--|
| <input type="checkbox"/> Catalog No. 8763 50" width. |
| <input type="checkbox"/> Catalog No. 8764 64 1/2" width. |
| <input type="checkbox"/> Catalog No. 8765 79" width. |

F. Extension shelf. Stainless steel. Mounted flush with top of module. Self mounting. 16" wide x 28" deep.

- | |
|--|
| <input type="checkbox"/> Catalog No. 8754. |
|--|

G. "Mateflat" Panel. (Makes any Galley unit compatible with any other serving line equipment or for squaring unit into wall.) Size: 5 3/8"W x 28"D x 36"H.

- | |
|---|
| <input type="checkbox"/> Catalog No. 8761 Male Panel (fits female end). |
| <input type="checkbox"/> Catalog No. 8762 Female Panel (fits male end). |

H. Flat End Panel.

- | |
|---|
| <input type="checkbox"/> Catalog No. 8731 Replaces Female "matelock". |
| <input type="checkbox"/> Catalog No. 8732 Replaces Male "matelock". |

I. Merchandising Shelf.

- | |
|---|
| <input type="checkbox"/> Catalog No. 8722. Use with 50" unit. |
| <input type="checkbox"/> Catalog No. 8713. Use with 64 1/2" unit. |
| <input type="checkbox"/> Catalog No. 8714. Use with 79" unit. |

J. Low End Shelf.

- | |
|--|
| <input type="checkbox"/> Catalog No. 8725. |
|--|

K. Bullet Feet.

- | |
|--|
| <input type="checkbox"/> Catalog No. 8783. |
|--|

NOTE: If unit is to be used independently, add 4" to width for clearance on all specifications. Add 3 1/2" to depth for folded trayslide and 3 1/4" for folded cutting board.

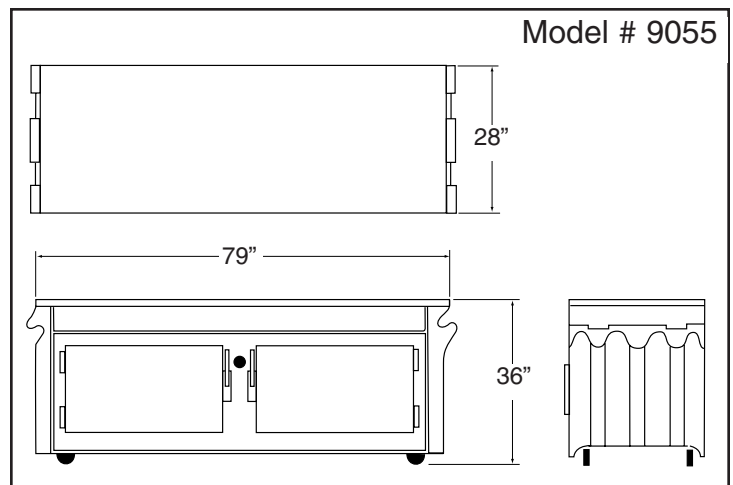
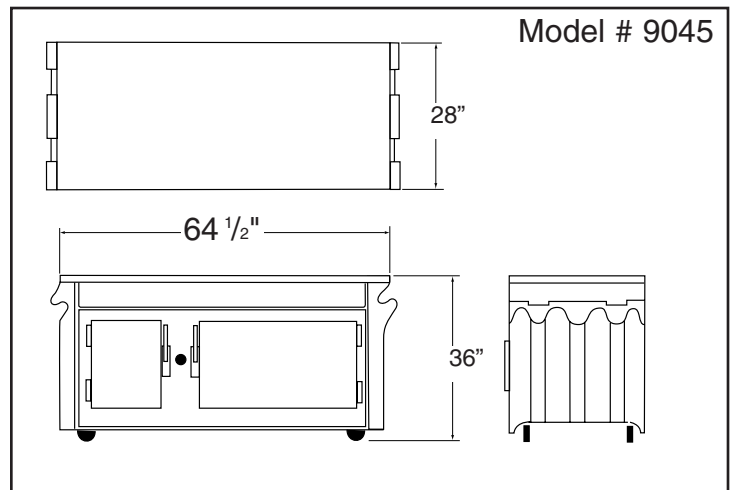
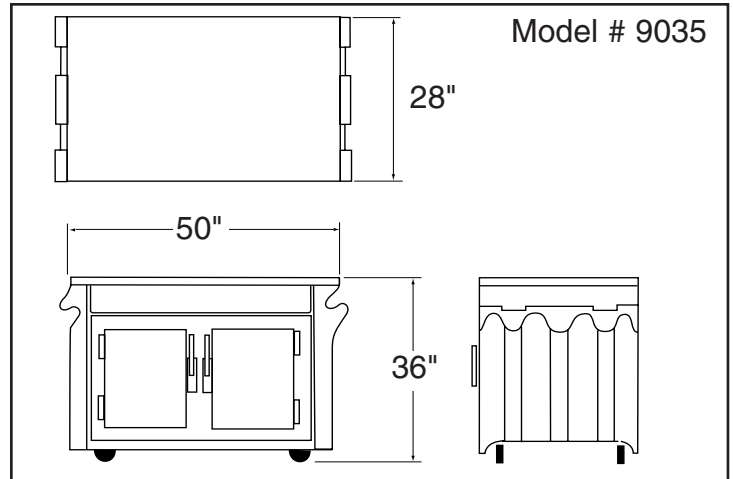

Specifications subject to change without notice.