

# Galley® Line

Sanitary, Heavy Duty  
**Self-Service 5" Deep  
 Cold Pan Food Modules  
 NSF Standard 2 Version**

Item No. \_\_\_\_\_

**Model No. 9130**

**Model No. 9140**

**Model No. 9150**

A1A11420



U.S. Patent No's. 4,013,880 and 4,008,931



**COLD PAN MODULE** – For keeping salads, fruits and other foods fresh and nutritious all through serving hours. Mechanical refrigeration units are also available.

- Aesthetic design, three neutral colors, dove white, pewter tan or black pearl, blends in with any surroundings.
- Four built-in & concealed stainless steel handles allow easy portability.
- Self-locking and self-aligning features eliminate time consuming hookup.
- Lightweight but extra-strong construction provides ease of mobility.
- Casters and brakes are almost completely concealed from patron's view.
- Soft textured surfaces and rounded corners help prevent skin cuts and clothing snags.



Cat. No.	Module Size			Pan Size			Quantity of Decorator Panels Included	Shpg. Wt. Lbs.
	W	D	H	W	D	H		
9130	50"	28"	36"	41"	19 <sup>7</sup> / <sub>8</sub> "	5"	3	205
9140	64 <sup>1</sup> / <sub>2</sub> "	28"	36"	55 <sup>1</sup> / <sub>2</sub> "	19 <sup>7</sup> / <sub>8</sub> "	5"	4	245
9150	79"	28"	36"	70"	19 <sup>7</sup> / <sub>8</sub> "	5"	5	305

\*Have Removable Drain Base.

To be **Galley® Line** Cold Pan Unit, Model \_\_\_\_\_ with accessories as specified.

**GENERAL:** Unit to be self-contained, mobile Cafeteria Cold Pan module for refrigerator temperature foods. Body material to be one of three neutral base colors, dove white, pewter tan or black pearl. "Matelock" self-locking and aligning end panels allow modules to be interconnected. To have recessed push handles at each end. Removable side panel on customer's side to be recessed to accept decorator panels. Server's side to be open to accept accessories. To be listed by National Sanitation Foundation, Standard 2.

**CONSTRUCTION:** Body material to be of flame retardant ABS formed plastic fastened to galvaneal under-carriage. 14 ga. 300 series stainless steel top to have not less than #4 finish. Cold pan to be constructed of stainless steel with shut-off valve and insulated with foamed urethane insulation approximately 1" thick. To have removable white low gloss ABS plastic drain base. Plate mounted 4" diameter swivel casters with toe brakes to be provided.

# Galley® Line Cold Pan Food Modules Model No's. 9130, 9140, 9150

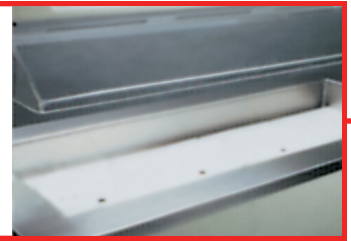

## SPECIFICATION DRAWING OF BASIC UNIT WITH DOUBLE DECK DISPLAY STAND, FOLDING TRAYSLIDE AND FOLDING CUTTING BOARD ACCESSORIES.



TOP VIEW SHOWN WITHOUT DOUBLE DECK DISPLAY STAND.  
DASHED LINES INDICATE USABLE INSIDE STORAGE.

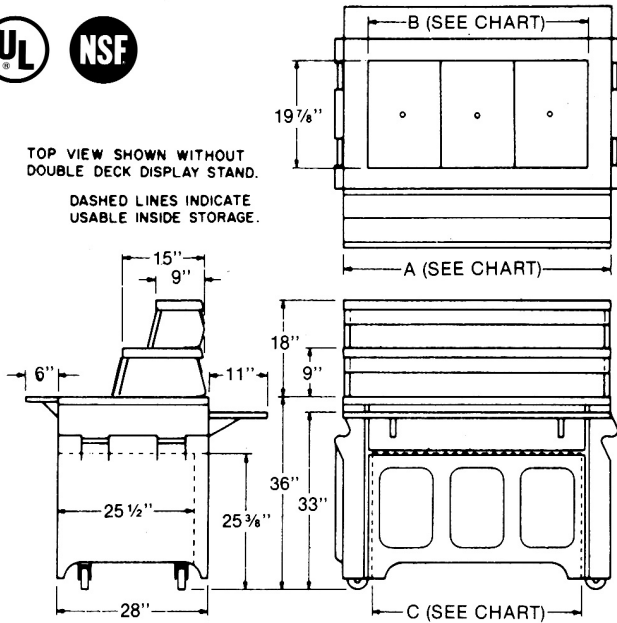

Cat. No.	Dim 'A'	Dim 'B'	Dim 'C'
9130	50"	41"	39"
9140	64 1/2"	55 1/2"	53 1/2"
9150	79"	70"	68"

**NOTE:** If unit is to be used independently, add 4" to width for clearance on all specifications. Add 3 1/2" to depth for folded trayslide and 3 1/4" for folded cutting board.

### ACCESSORIES:

- A.** Decorator panels, specify catalog number and quantity. (See chart on front side.)
- Catalog No. 8700 American Walnut, Quantity \_\_\_\_\_ Included.
  - Catalog No. 8701 Teakwood, Quantity \_\_\_\_\_.
  - Catalog No. 8702 Plain Custom Panel, Quantity \_\_\_\_\_.
- B.** Food Pan Adapters. Adapter bar for use when 12 x 20 pans are placed in cold pan to cover top opening. Specify quantity.
- Catalog No. 8751. Quantity \_\_\_\_\_.
- C.** Folding Trayslides. All stainless steel with die-stamped three-rib reinforcement.
- Catalog No. 8773, (\*Short 50") 42 7/8" width, used on 9130.
  - Catalog No. 8774, 50" width, used on 9130.
  - Catalog No. 8775, (\*Short 64 1/2") 57 3/8" width, used on 9140.
  - Catalog No. 8776, 64 1/2" width, used on 9140.
  - Catalog No. 8777, (\*Short 79") 71 7/8" width, used on 9150.
  - Catalog No. 8778, 79" width, used on 9150.

\*Note: A short trayslide must be used on the first module to the right of Corner In-Fill Module for inside turns.

- D.** Food Protector with plastic shelf, breathguard and stainless steel upright supports. 14" high.
- Catalog No. 8780, 50" width used on 9130. Unlighted.

- Catalog No. 8791, 50" width used on 9130. Lighted. UL Listed.
  - Catalog No. 8781, 64 1/2" width used on 9140. Unlighted.
  - Catalog No. 8792, 64 1/2" width used on 9140. Lighted. UL Listed.
  - Catalog No. 8782, 79" width used on 9150. Unlighted.
  - Catalog No. 8793, 79" width used on 9150. Lighted. UL Listed.
- E.** Double-Deck Display stand with two plastic shelves, breathguards and stainless steel upright supports, 18" high.
- Catalog No. 8785, 50" width used on 9130. Unlighted.
  - Catalog No. 8788\*, 50" width used on 9130. Lighted. UL Listed.
  - Catalog No. 8786, 64 1/2" width used on 9140. Unlighted.
  - Catalog No. 8789, 64 1/2" width used on 9140. Lighted. UL Listed.
  - Catalog No. 8787, 79" width used on 9150. Unlighted.
  - Catalog No. 8790, 79" width used on 9150. Lighted. UL Listed.
- F.** Folding Cutting Board. All plastic. Mounted flush on server's side.
- Catalog No. 8763, 50" width, used on 9130.
  - Catalog No. 8764, 64 1/2" width used on 9140.
  - Catalog No. 8765, 79" width used on 9150.
- G.** Extension shelf. Stainless steel. Mounted flush with top of module. Self-mounting. 16" wide x 28" deep.
- Catalog No. 8754, (Not for use with item J or N).
- H.** Undercounter Shelving System. Maximum: two per unit. All stainless steel. Removable. 18" depth with 1" front edge.
- Catalog No. 8757, 41 1/2" width used on 9130.
  - Catalog No. 8758, 56 1/16" width used on 9140.
  - Catalog No. 8759, 70 1/2" width used on 9150.
- I.** Utility Drawer. Stainless steel. Has lock and removable liner. Outside dimensions: 25 1/4"W x 23"D x 7 1/4"H. Mounted on server's side.
- Catalog No. 8760.
- J.** "Mateflat" Panel. (Makes any Galley unit compatible with any other serving line equipment or for squaring unit to wall.) Size 5 3/8"W x 28"D x 36"H.
- Catalog No. 8761. Male panel (fits female end).
  - Catalog No. 8762. Female panel (fits male end).
- K.** Buffet Style Canopy.
- Catalog No. 8740\*, used with 50" width unit.
  - Catalog No. 8741\*, used with 64 1/2" width unit.
  - Catalog No. 8742, used with 79" width unit.
- L.** Low End Shelf. (Not for use with item J or N).
- Catalog No. 8725.
- M.** Close Off for server's side.
- Catalog No. 8734, used with 50" width unit.
  - Catalog No. 8735, used with 64 1/2" width unit.
  - Catalog No. 8736, used with 79" width unit.
- N.** Flat End Panel. (Makes any Galley unit compatible with any other serving line equipment or for squaring unit to wall.)
- Catalog No. 8731 Replaces Female "matelock"
  - Catalog No. 8732 Replaces Male "matelock".
- \*Lighted accessories are UL listed.
- O.** Electrical Outlets (Not UL listed).
- Catalog No. 8696 Tombstone, Top Mounted, Duplex, 125V 15 AMP.
  - Catalog No. 8678 Operator Side, Under Top Skirt, Duplex, 120V 16 AMP.
  - Catalog No. 8698 Operator Side, Under Top Skirt, Duplex, 120V 15 AMP.
  - Catalog No. 8699 Operator Side, Under Top Skirt, Single, 120V 15 AMP.
- NOTE:** #8696 and #8697 are part of the module wiring. #8698 and #8699 have separate cord set.