

Galley® Line

Sanitary, Heavy Duty
Stainless Steel Counters
with Refrigerators &
Freezers

Item No. _____

Model No. 9361
Model No. 9362
Model No. 9363
Model No. 9364
Model No. 9365
Model No. 9366

A1A11420

50" MODULE



9361 REFRIGERATOR, 9364 FREEZER

64 1/2" MODULE



9362 REFRIGERATOR, 9365 FREEZER

79" MODULE



9363 REFRIGERATOR, 9366 FREEZER

U.S. Patent No's. 4,013,880/ Des. 244,735

- Aesthetic design, three neutral colors, dove white, pewter tan, or black pearl blend in with any surroundings.
- Energy efficient, forced air refrigeration system.
- Four built-in & concealed stainless steel handles allow easy portability.
- Forced air system for rapid pull down.
- Self-locking and self-aligning features eliminate time consuming hookup.
- Lightweight but extra-strong construction provides ease of mobility.
- Casters and brakes are almost completely concealed from patron's view.
- Soft textured surfaces and rounded corners help prevent skin cuts and clothing snags.
- Stainless steel tops and doors.
- Stainless steel interior.
- Self-closing doors.
- Two epoxy coated steel adjustable shelves.
- Lift out refrigeration system.

To be **Galley® Line** Module _____
with accessories as specified.

GENERAL: Unit to be self-contained, mobile under-counter refrigeration module accessible from one side only. Body material to be one of three neutral base colors, dove white, pewter tan or black pearl. "Matelock" self-locking and aligning end panels allow modules to be interconnected. To have recessed push handles at each end. Side skirt (customer side) to be removable for access to electrical junction box and refrigerator base. Side skirt to be recessed to accept decorator panels. To be listed by the National Sanitation Foundation.

CONSTRUCTION: Body material to be of flame retardant ABS formed plastic fastened to a galvanized steel undercarriage. 14 ga. 300 series stainless steel top to have not less than No. 4 finish. Inner liner of refrigerator constructed of aluminum. Refrigeration system to be hermetically sealed condensing unit with blower coil. System preset to maintain proper product temperature. Plate mounted 4" diameter swivel casters with toe brakes. Power supply cord to be 6 feet in length. NEMA plug configuration to be 5-15P. To be used with a branch circuit rating of 15 AMPS, single pole. Power supply cord to be 14 AWG, 3 conductors. Doors fully insulated with concealed and self-closing hinges. Complete with moisture proof door gasket, and two adjustable shelves. Automatic condensation evaporator.

Galley® Line

Stainless Steel Counters with Refrigerators or Freezers Model No's. 9361, 9362, 9363, 9364, 9365, 9366

ACCESSORIES:

- A.** Decorator panels, specify catalog number and quantity.
- Catalog No. 8700 American Walnut, Quantity_____.
 - Catalog No. 8701 Teakwood, Quantity_____.
 - Catalog No. 8702 Plain Custom Panel, Quantity_____.
 - Catalog No. 8705A Light Oak, Quantity_____.

- B.** Folding Trayslides. All stainless steel with die-stamped three-rib reinforcement.

- Catalog No. 8774, 50" width.
- Catalog No. 8775, (*Short 64 1/2") 57 3/8" width.
- Catalog No. 8776, 64 1/2" width.
- Catalog No. 8777, (*Short 79") 71 7/8" width.
- Catalog No. 8778, 79" width.

***Note:** A short trayslide must be used on the first module to the right of Corner In-Fill Module for inside turns.

- C.** Food Protector with plastic shelf, breathguard and stainless steel upright supports. 14" high. Must be factory ordered with the refrigeration module.

- Catalog No. 8780, 50" width. Unlighted.
- Catalog No. 8791, 50" width. Lighted.
- Catalog No. 8781, 64 1/2" width. Unlighted.
- Catalog No. 8792, 64 1/2" width. Lighted.
- Catalog No. 8782, 79" width. Unlighted.
- Catalog No. 8793, 79" width. Lighted.

- D.** Double Deck Display Stand with two plastic shelves, breathguard and stainless steel upright supports. 18" high. Must be factory ordered with the refrigeration module.

- Catalog No. 8785, 50" width. Lighted.
- Catalog No. 8786, 64 1/2" width. Unlighted.
- Catalog No. 8789, 64 1/2" width. Lighted.
- Catalog No. 8787, 79" width. Unlighted.
- Catalog No. 8788, Unlighted.
- Catalog No. 8790, 79" width. Lighted.

- E.** Extension shelf. Stainless steel. Mounted flush with top of module. Self-mounting. 16" wide x 28" deep.

- Catalog No. 8754.

- F.** "Mateflat" Panel. (Makes any Galley unit compatible with any other serving line equipment or for squaring unit to wall.)
Size 5 3/8"W x 28"D x 36"H.

- Catalog No. 8761 Male Panel (Fits female end).
- Catalog No. 8762 Female Panel (Fits male end).

- G.** Flat End Panels.

- Catalog No. 8731 Replaces Female "Matelock"
- Catalog No. 8732 Replaces Male "Matelock".

- H.** Merchandising Shelf.

- Catalog No. 8722. Use with 50" unit.
- Catalog No. 8713. Use with 64 1/2" unit.
- Catalog No. 8714. Use with 79" unit.

- I.** Low End Shelf.

- J.** Bullet Feet.

- Catalog No. 8725.
- Catalog No. 8783.

NOTE: If unit is to be used independently, add 4" to width for clearance on all specifications and add 3/2" to depth for folded trayslide.

Specifications subject to change without notice.

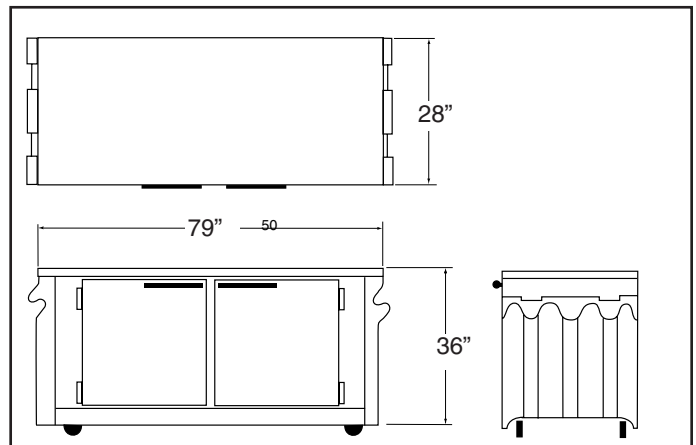
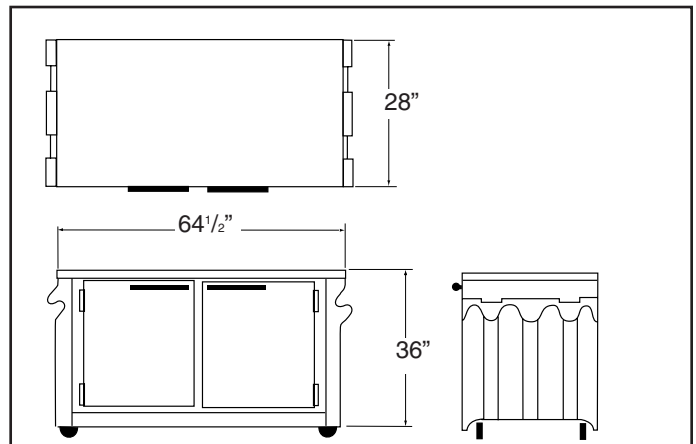
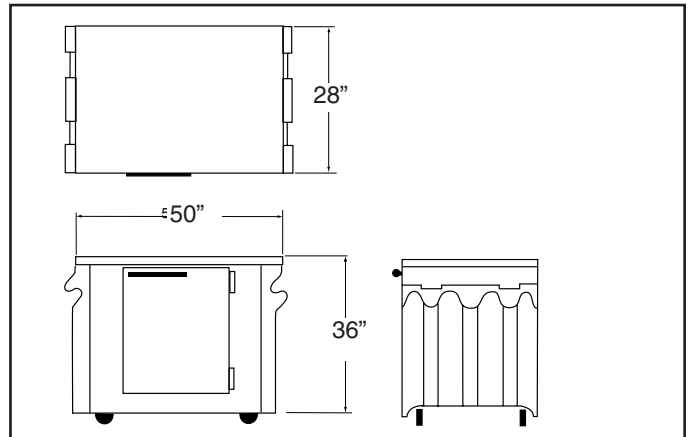

Cat. No.	Type	Panels	Width	Depth	Height	Capacity		Volts	Amps	Phase	Hz	Weight Lbs.
						Cu. Ft.	Sq. Ft.					
9361*	Refrig.	3	50"	28"	36"	7.3	8.1	115	6.6	60	1	350
9362**	Refrig.	4	64 1/2"	28"	36"	12.0	13.5	115	6.6	60	1	450
9363**	Refrig.	5	79"	28"	36"	15.9	17.7	115	9.3	60	1	500
9364*	Freezer	3	50"	28"	36"	7.3	8.1	115	7.1	60	1	350
9365**	Freezer	4	64 1/2"	28"	36"	12.0	13.5	115	7.1	60	1	450
9366**	Freezer	5	79"	28"	36"	15.9	17.7	115	9.3	60	1	500

*Single Door **Double Door All with Nema 5-15P Plugs