

Galley® Line

Sanitary, Heavy Duty
Portable Griddle Modules

Item No. _____

Model No. 9439
Model No. 9449
Model No. 9459
Model No. 9438
Model No. 9448
Model No. 9458

A1A11420



The Galley Portagriddle – Designed to be used in the Galley cafeteria serving line for the preparation of grilled foods at breakfast, lunch or dinner. Portagriddle puts greater flexibility into cafeteria menus because foods can be grilled “on the spot” to suit patron’s tastes. Unit includes 25” or 36” griddle, left-hand mounted (from server’s side). 208V or 240V, 3 phase.

- Aesthetic design, three neutral colors, dove white, pewter tan or black pearl, blends in with any surroundings.
- Four built-in & concealed stainless steel handles allow easy portability.
- Self-locking and self-aligning features eliminate time consuming hookup.
- Lightweight but extra-strong construction provides ease of mobility.
- Casters and brakes are almost completely concealed from patron’s view.
- Soft textured surfaces and rounded corners help prevent skin cuts and clothing snags.

U.S. Patent No's. 4,013,880/ Des. 244,735
Model 9439 shown with grill mounted toward male end.



Catalog No.	Griddle Width	Width	Depth	Height	Working Flat Width	Quantity of Decorator Panels Required	Shipping Weight
9439	25"	50"	28"	36"	20"	3	500
9449	25"	64 1/2"	28"	36"	34 1/2"	4	600
9459	25"	79"	28"	36"	49"	5	700
9438	36 1/2"	50"	28"	36"	6 3/4"	3	550
9448	36 1/2"	64 1/2"	28"	36"	21 1/4"	4	650
9458	36 1/2"	79"	28"	36"	35 3/2"	5	750

Galley® Line Portable Griddle Module

Model No's. 9439, 9449, 9459, 9438, 9448, 9458

To be **Galley® Line** Griddle Module _____ with accessories as specified.

GENERAL: Unit to be self-contained, mobile cafeteria Hot Griddle Module for food preparation. Body material to be one of three neutral base colors, dove white, pewter tan or black pearl. "MATE-LOCK" self-locking and aligning end panels allow modules to be interconnected. To have recessed push handles at each end. Removable side panel on customer's side to be recessed to accept decorator panels. Server side to be open to accept accessories. To be listed by Underwriter's Laboratories, Inc. and National Sanitation Foundation.

CONSTRUCTION: Body material to be of flame retardant ABS formed plastic fastened to a galvanneal undercarriage. 14 ga. 300 series stainless steel top to have not less than #4 finish.

GRIDDLE: Controlled by dual-variable thermostats with signal lights. Top is one-half inch thick polished steel.

ACCESSORIES:

A. Decorator panels, specify catalog number and quantity. (See chart on front side).

- Catalog No. 8700 American Walnut, Quantity _____.
- Catalog No. 8701 Teakwood, Quantity _____.
- Catalog No. 8702 Plain Custom Panel, Quantity _____.
- Catalog No. 8703 White, Quantity _____.
- Catalog No. 8705 Light Oak, Quantity _____.

B. Folding Trayslides. All stainless steel with die-stamped three-rib reinforcement.

- Catalog No. 8773, (*Short 50") 42 7/8" width.
- Catalog No. 8774, 50" width.
- Catalog No. 8775, (*Short 64 1/2") 57 3/8" width.
- Catalog No. 8776, 64 1/2" width, used on 9340.
- Catalog No. 8777, (*Short 79") 71 7/8" width.
- Catalog No. 8778, 79" width.

***Note:** A short trayslide must be used on the first module to the right of Corner In-Fill Module for inside turns.

C. Folding Cutting Board. All plastic. Mounted flush on server's side.

- Catalog No. 8737, 50" width.
- Catalog No. 8738, 64 1/2" width.
- Catalog No. 8739, 79" width.

D. Extension shelf. Stainless steel. Mounted flush with top of module. Self-mounting. 16" wide x 28" deep.

- Catalog No. 8754.

E. Hot Food Protector with plastic shelf, breathguard and chrome plated upright supports. 14" high. Field mounted.

- Catalog No. 8780, 50" width.
- Catalog No. 8781, 64 1/2" width.
- Catalog No. 8782, 79" width.

F. Lighted Hot Food Protector with breathguard and chrome plated upright supports. 14" high. Field mounted. Bulbs with plastic protective sheaths included. 120V, 1 phase, 60 Hz.

- Catalog No. 8791, 50" width, 0.6 Amps, 30 Watts.
- Catalog No. 8792, 64 1/2" width, 0.7 Amps, 36 Watts.
- Catalog No. 8793, 79" width, 0.8 Amps, 38 Watts.

Note: when specifying an accessory with a different voltage than the basic unit, the overall unit rating will be the combination of the two. For example: A 208V unit such as Model No. 9439 with an 8791 Lighted Hot Food Protector would be rated at 120/208V. To specify the overall unit wattage, add unit watts to accessory watts. Amps will remain the same.

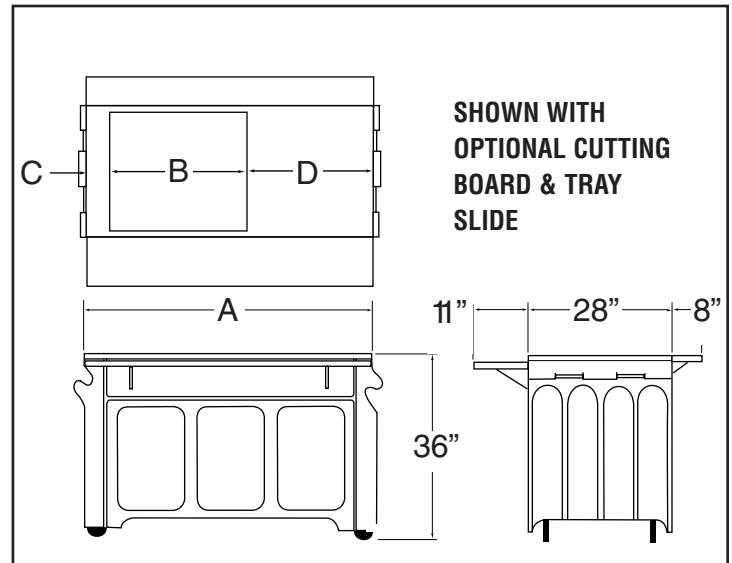

G. Utility Drawer. Stainless steel. Has lock and removable liner. Outside dimensions: 25 1/2"W x 23"D x 7 1/4"H. Mounted.

- Catalog No. 8760. Fits all models.

H. Undercounter Shelving System. Maximum: two per unit. All stainless steel. Removable. 18" depth with 1" front edge.

- Catalog No. 8757, 41 1/2" width, used on 50" model.
- Catalog No. 8758, 56 1/16" width, used on 64 1/2" model.
- Catalog No. 8759, 70 1/2" width, used on 79" model.

I. "Mateflat" Panel. (Makes any Galley unit compatible with any other serving line equipment or for squaring unit to wall.) Size 5 3/8"W x 28"D x 36"H.

- Catalog No. 8761 Male Panel (Fits female end).
- Catalog No. 8762 Female Panel (Fits male end).

Specifications subject to change without notice.

Electrical Information

9438, 9448, 9458

36" Griddles

Volts	KW	Amps Per Line Three Phase			Amps 1 Phase
		L1	L2	L3	
208	12	28.8	49.9	28.8	57.6
240	12	25.0	43.3	25.0	50.0
480	12	10.8	21.6	10.8	25.0

Electrical Information

9439, 9449, 9459

25" Griddles

Volts	KW	Amps Per Line Three Phase			Amps 1 Phase
		L1	L2	L3	
208	7.2	14.0	28.1	14.0	37.5
240	9.0	18.7	32.5	18.7	32.5
480	9.0	8.1	16.2	8.1	18.7